

- SMA connector, SP3T

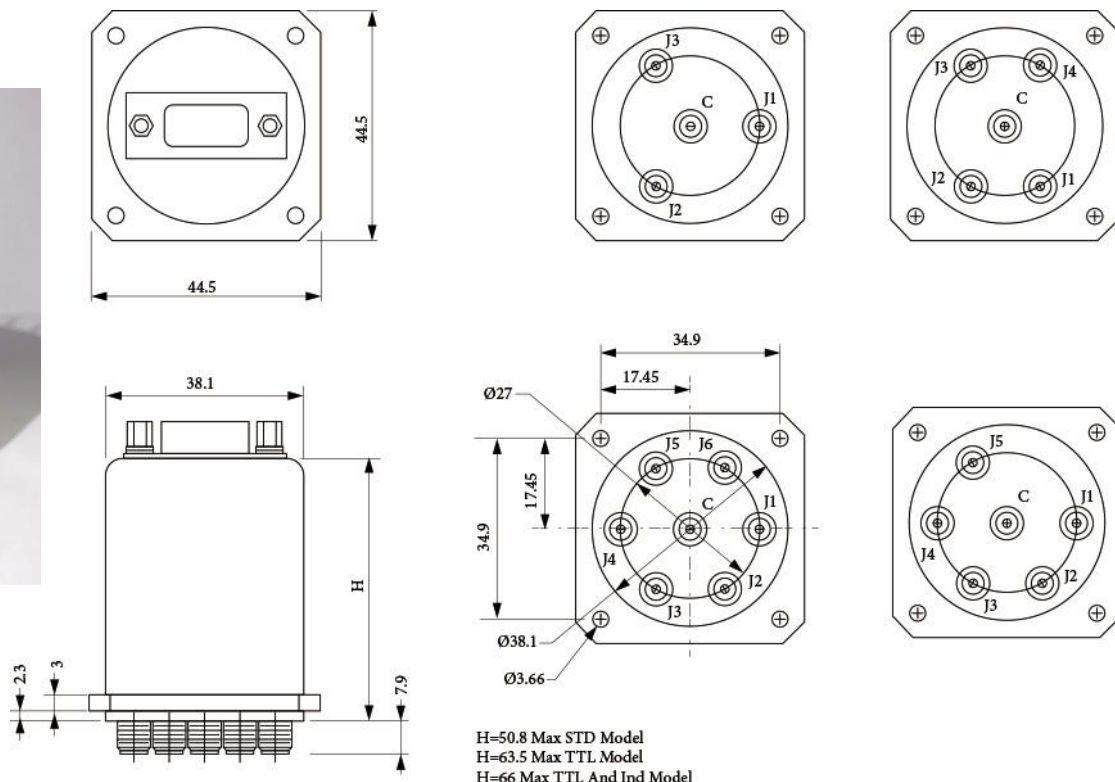

### SPMT Normally Open

#### Standard

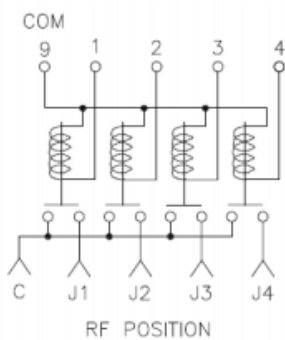

#### TTL

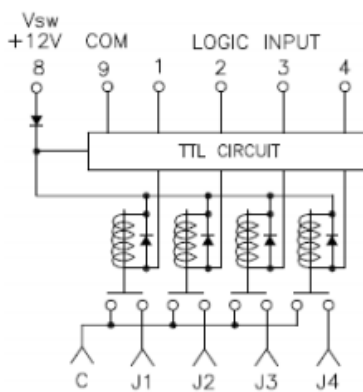

#### Indicator + TTL

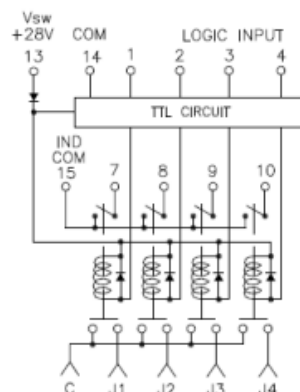

#### TTL + Internal Termination

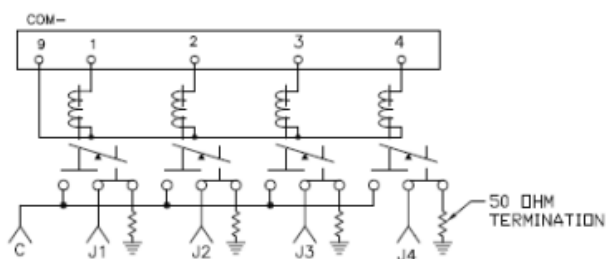

#### Indicator + TTL + Internal Termination

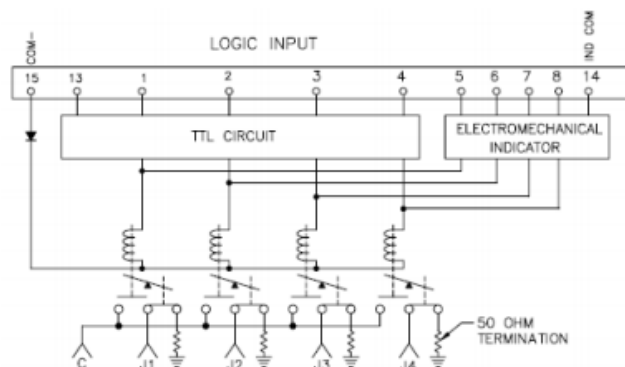

Electrical Specifications	
Operating Frequencies	DC to 26.5 GHz
VSWR	1.25 @ DC to 6 GHz 1.40 @ 6 to 12 GHz 1.50 @ 12 to 18 GHz 1.80 @ 18 to 22 GHz 1.80 @ 22 to 26.5 GHz
Isolation	70 dB @ DC to 6 GHz 60 dB @ 6 to 12 GHz 60 dB @ 12 to 18 GHz 50 dB @ 18 to 22 GHz 50 dB @ 22 to 26.5 GHz
Insertion Loss	0.2 dB @ DC to 6 GHz 0.4 dB @ 6 to 12 GHz 0.5 dB @ 12 to 18 GHz 0.8 dB @ 18 to 22 GHz 0.8 dB @ 22 to 26.5 GHz
Actuator Voltage	12 VDC
Actuator Current	220 mA
Switching Time	20 MS
MTBF	6.5 Million Hours
Power Connector	ITT KPT02E12-10P Mating connector provided
Connectors	SMA(F)
Actuator type	A: Normally open without Indicator B: Normally open with Indicator
Options	D: TTL with Suppression Diode T: Internal Terminations -SMA models only
Operating Life MTBF	1 Million Cycles MIL-HDBK-217F Fixed, 25°C, <1 Cycle per hour
Characteristic Impedance	50 Ω (75 Ω available for SPDT upon request)
Operating Temperature	-25 to+65°C
Humidity	Moisture Seal Available
Shock	MIL-STD-202 Method 213,Condition D(500G Non Operation)

**Part Number Selection**

