

- N connector, SP3T

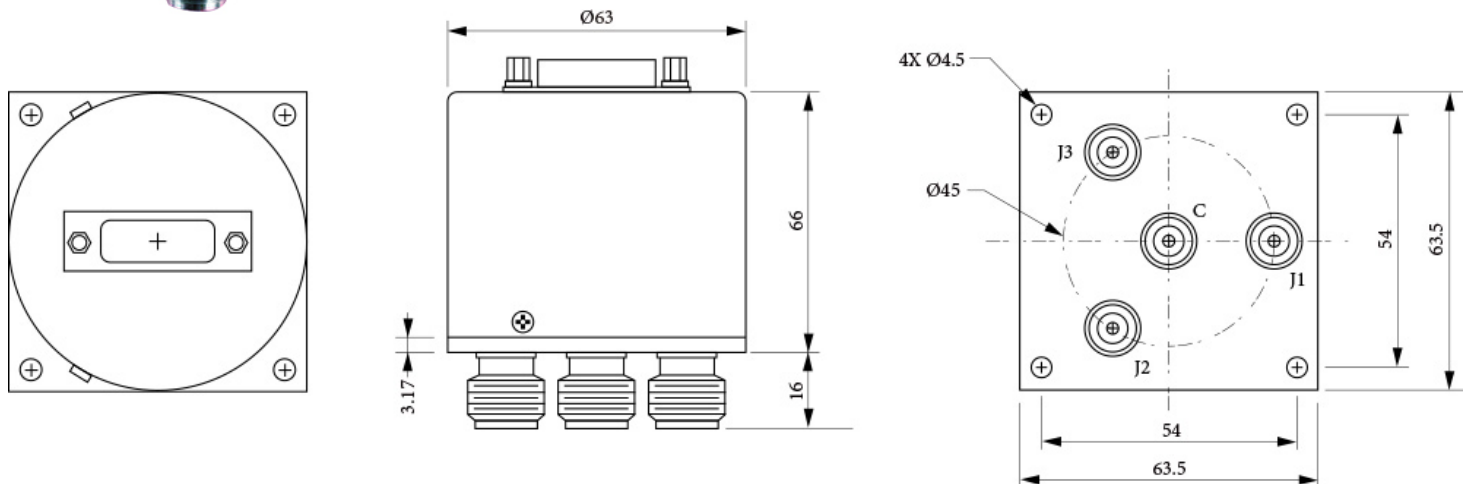

**SPMT Normally Open**

Standard

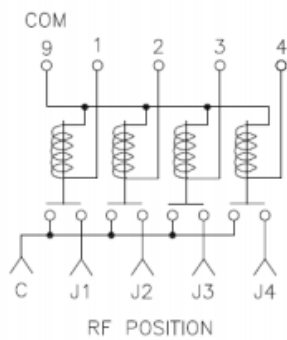

TTL

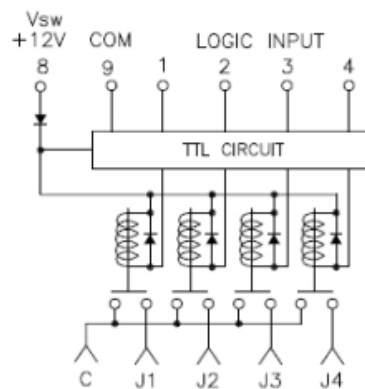

Indicator + TTL

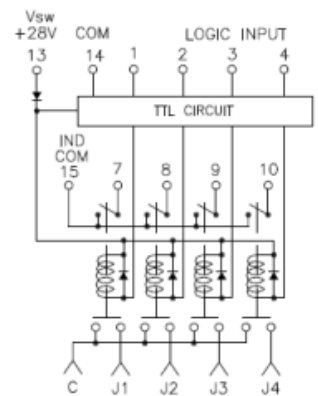

TTL + Internal Termination

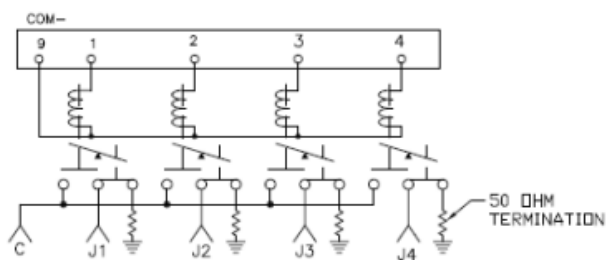

Indicator + TTL + Internal Termination

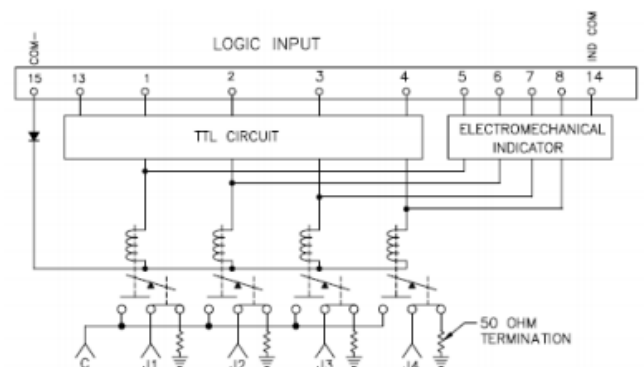

Electrical Specifications	
Operating Frequencies	DC to 11 GHz
VSWR	1.25 @ DC to 1 GHz 1.40 @ 1 to 4 GHz 1.45 @ 4 to 8 GHz 1.70 @ 8 to 11 GHz
Isolation	70 dB @ DC to 1 GHz 60 dB @ 1 to 4 GHz 60 dB @ 4 to 8 GHz 60 dB @ 8 to 11 GHz
Insertion Loss	0.3 dB @ DC to 1 GHz 0.4 dB @ 1 to 4 GHz 0.4 dB @ 4 to 8 GHz 0.7 dB @ 8 to 11 GHz
Actuator Voltage	12 VDC
Actuator Current	220 mA
Switching Time	20 MS
MTBF	6.5 Million Hours
Power Connector	ITT KPT02E12-10P Mating connector provided
Connectors	N (F)
Actuator type	A: Normally open without Indicator B: Normally open with Indicator
Options	D: TTL with Suppression Diode T: Internal Terminations -SMA models only
Operating Life	1 Million Cycles MIL-HDBK-217F Fixed, 25°C, <1 Cycle per hour
Characteristic Impedance	50 Ω (75 Ω available for SPDT upon request)
Operating Temperature	-25 to+65°C
Humidity	Moisture Seal Available
Shock	MIL-STD-202 Method 213,Condition D(500G Non Operation)

**Part Number Selection**

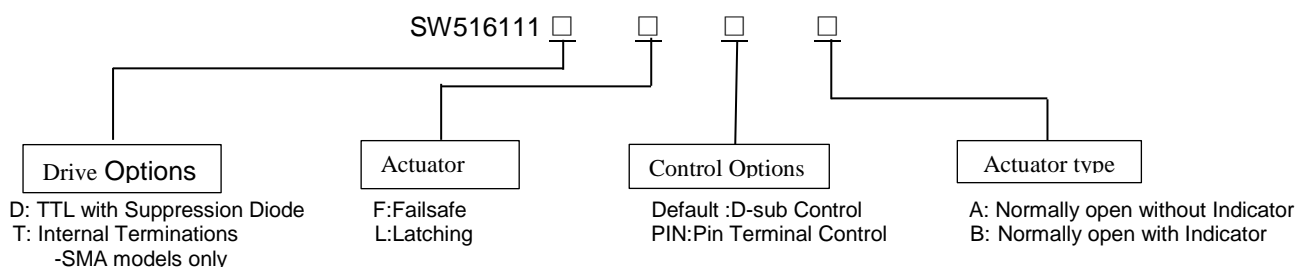

Yach reserves the right to change this Datasheet without notice!  
For special requirements,pls inquiry.